

THE NOTES ON A UKULELE

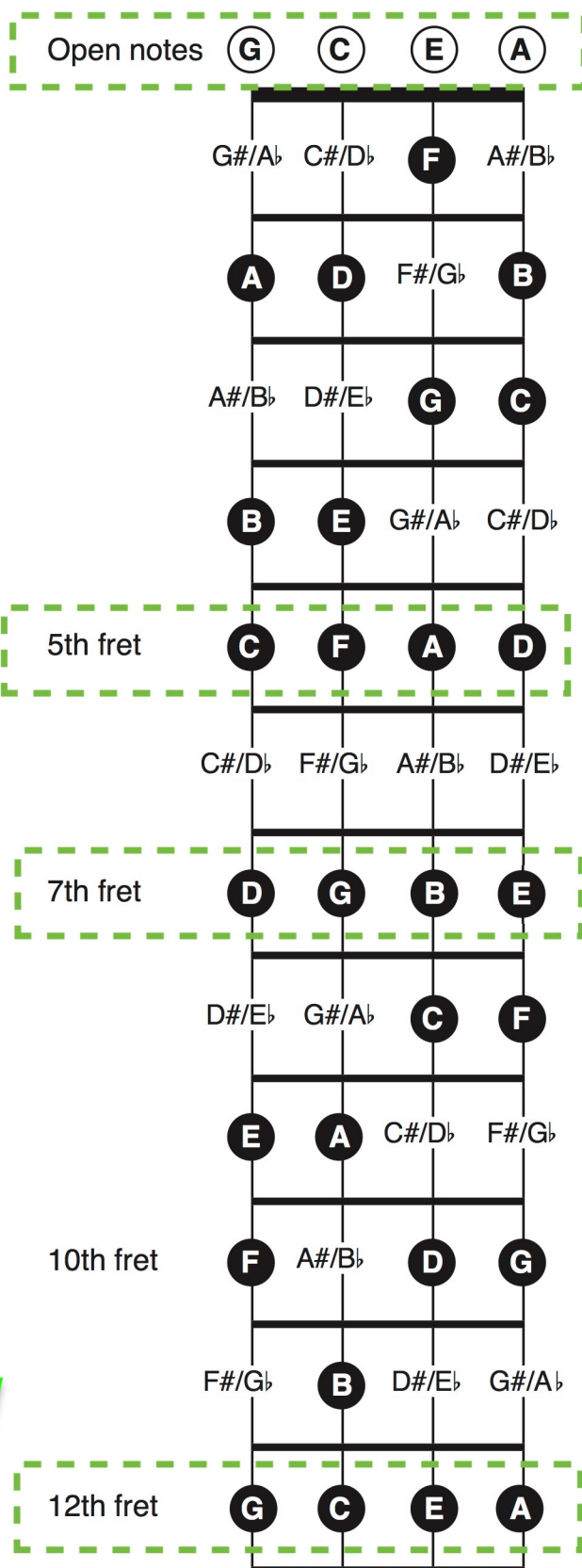

The circled letters mark where the notes of the C major scale can be found on the ukulele fretboard. Notes in the spaces without a circled letter are also used for many scales and chords. They are named by using a sharp (#) or a flat (♭). For example, the note on the first fret of the A string can be called either A sharp (A#) or B flat (B♭). The note on the second fret of the E string can be called either F sharp (F#) or G flat (G♭). When learning the notes on the fretboard, I suggest students start out by learning the location of the notes of the C major scale. They can then easily learn to name the remaining notes using sharps or flats.

Learn these
"MERIDIANS"

Same as the
open notes!